

- |                          |                     |                  |
|--------------------------|---------------------|------------------|
| 1 Faro                   | 7 Volante magnético | 13 Fusibles 15 A |
| 2 Cuenta rpm - Cuenta km | 8 Batería 6 V       | 14 Bujías        |
| 3 Stop delantero         | 9 Ruptor            | 15 Bobina        |
| 4 Claxon                 | 10 Conmutador       | 16 Regulador     |
| 5 Stop trasero           | 11 Llave contacto   |                  |
| 6 Piloto trasero         | 12 Regla conexiones |                  |

**INSTALACION ELECTRICA**  
**250-350 ROAD**

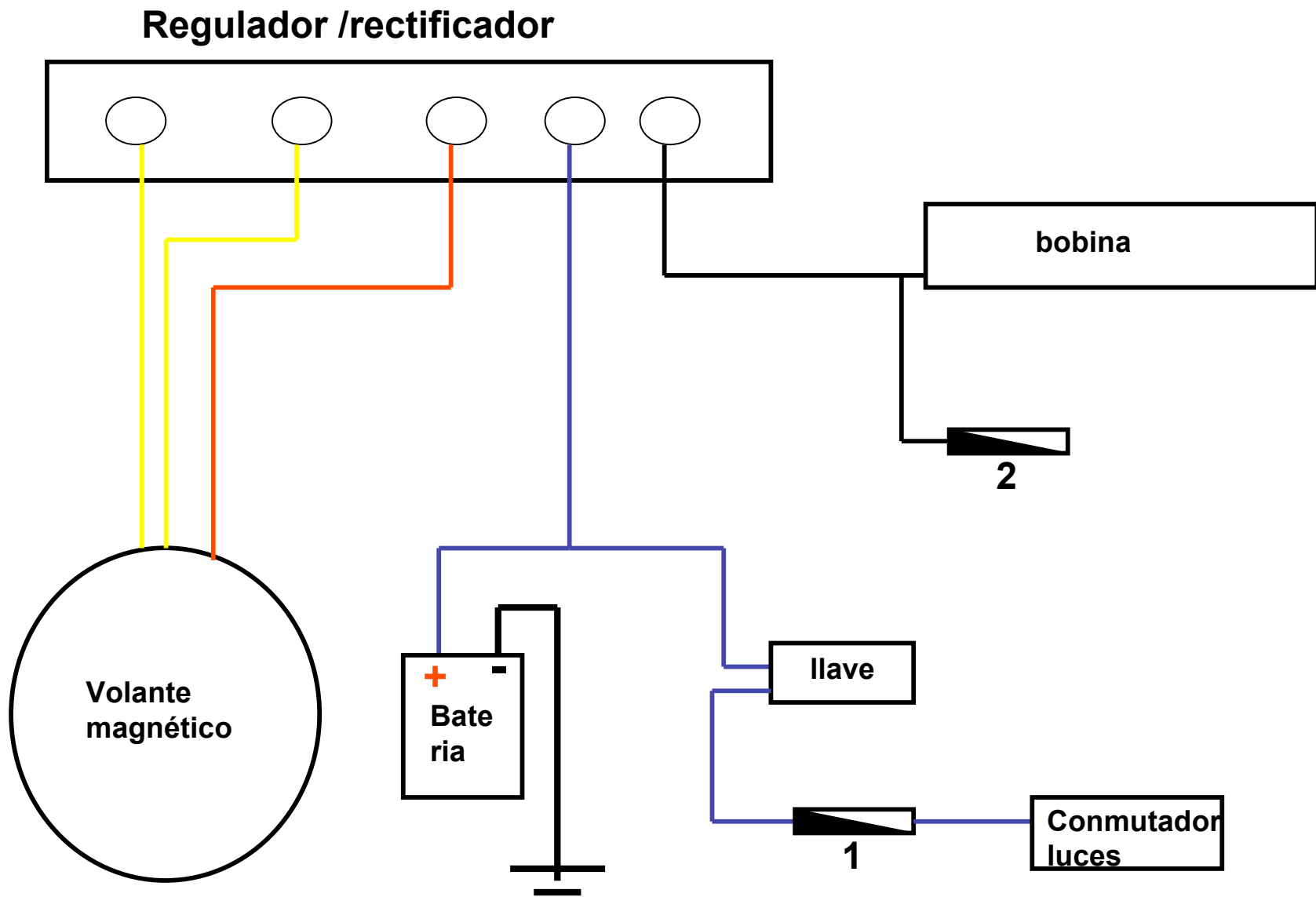

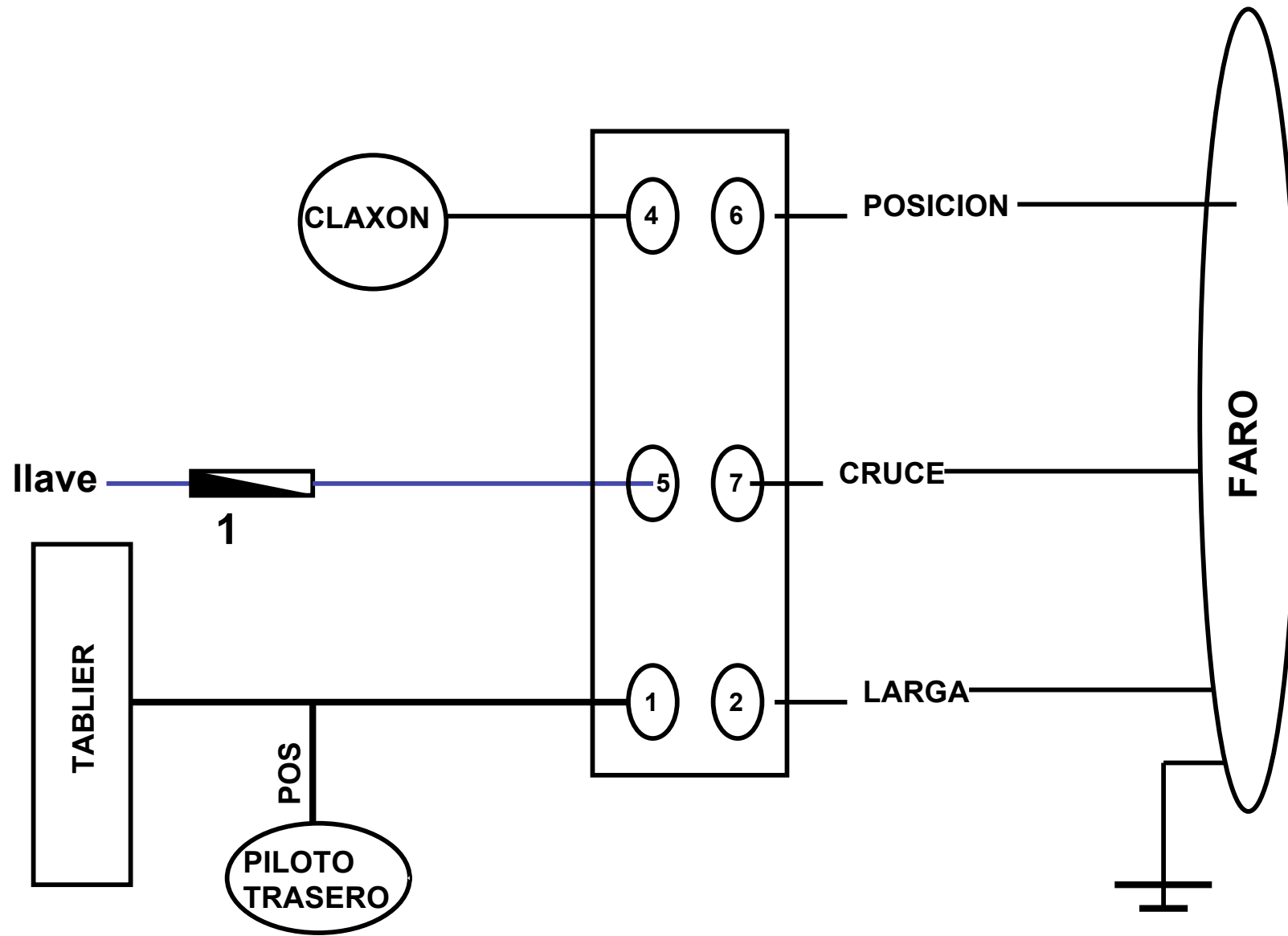

### ESQUEMA CONEXIONES COMUTADOR DE LUCES DUCATI 250 ROAD

<----- Dirección de la marcha

